

T342S/T392SE/T392S







Carrozzeria interamente in acciaio inox 18/10 Aisi 304, doppia parete.
Pompa di lavaggio Hp.0,21/Hp.0,42.
Boiler incorporato in acciaio dotato di termostato di sicurezza.
Resistenza vasca. Carico vasca automatico.
Sicurezza porta. Dosatore brillantante
Costruzione secondo normative CE.

Complete stainless steel construction Aisi 304 18/10, double skin.
Wash pump Hp.0,21/Hp.0,42.
Heating boiler constructed of stainless steel with safety thermostat.
Tank heater. Automatic tank loading.
Door safety. Rinsing additives dosing pump.
Construction in accordance with the CE directives.

Carrosserie entièrement en acier inox 18/10 Aisi 304, double parois.
Pompe de lavage Hp.0,21/Hp.0,42.
Boiler chauffant en acier incorporé avec thermostat de sécurité.
Résistance cuve. Remplissage automatique de la cuve.
Porte sécurité. Doseur produit de rinçage.
Construction en conformité avec les directives CE.

Völlig aus rostfreiem Inox-Stahl 18/10 Aisi 304, komplett doppelwandig.
Waschpumpe Hp.0,21/Hp.0,42.
Eingebauter Kupferheizkessel mit Sicherheits-Thermostat.
Tank Heizkörper. Automatische Tankfüllung.
Tür-Sicherheit. Dosierapparat für Klarspüler.
Der Bau entsprechend den EG-Richtlinien.

					T342S	T392SE	T392S
Produzione oraria-cesti	Capacity p/hours-racks	Débit horaire paniers	Stundenleistung-Körbe	nr.	30	30	30
Durata ciclo	Wash cycle	Durée du cycle	Programmadauer	min.	2	2	2
Voltaggio	Voltage	Voltage	Spannung	V/Hz	230/50/1		
Potenza totale	Total power	Puissance totale	Gesamtverbrauch	Watt	2560	2560	3300
Resistenza boiler	Boiler heating element	Résistance boiler	Durchlauferhitzer	Watt	2400	2400	3000
Resistenza vasca	Tank heater	Résistance cuve	Tank-Heizkörper	Watt	1600	1600	1600
Pompa di lavaggio	Motor washing pump	Pompe de lavage	Waschpumpe	Watt	160	160	300
Capacità vasca	Tank capacity	Capacité de la cuve	Tankinhalt	Lt.	9	13	13
Capacità boiler	Boiler capacity	Capacité du boiler	Boilerinhalt	Lt.	3,0	3,0	4,5
Quantità acqua di risciacquo	Quantity of rinsing water	Quantité eau de rinçage	Quantität des Spülwasser	Lt.	1,7	2,2	2,2
Dimensioni cesto	Basket dimensions	Dimension du panier	Körbe Abmessung	mm.	Ø 350	Ø 390	Ø 390
Dotazione: cesto bicchieri cesto posate	Equipment: rack glasses cutlery insert	Dotation : panier a verres godet a couverts	Ausstattung: Gläserkorb Besteckkorb	Nr. Nr.	2 1	2 1	2 1

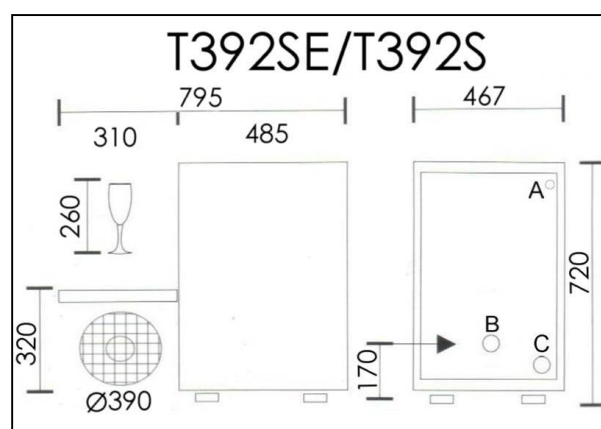
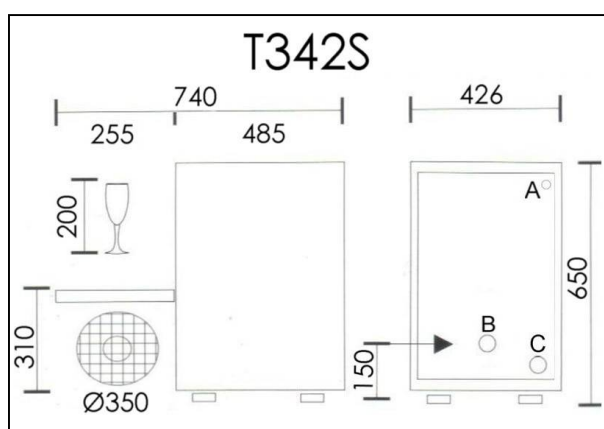

A Uscita cavo elettrico
Electric cable outlet
Sortie électrique câble
Elektrisches Kabel Ausgang
3x1.5/ 3x2.5 mm²

B Attacco scarico acqua
Water drain hose
Vidange eau
Abwasseranschluss
Ø 28

C Uscita tubo alimentazione acqua
Water supply hose outlet
Sortie du tuyau d'eau
Ausgang Wasserschlauch
Ø 3/4" GAS M

FABAR S.r.l. – Via S.Andrea, 97 – 25062 Concesio (BS) ITALY

Tel 030 2091270 – Fax 030 2091417

<http://www.fabar.it> – e-mail:info@fabar.it

P.Iva 03296880176

FABAR S.r.l. si riserva il diritto di apportare ai propri prodotti quelle modifiche che riterrà utili senza preavviso.

FABAR S.r.l. reserves the rights to make changes in his products without notice.

FABAR S.r.l. behält sich vor, soweit es für notwendig halt, Änderungen an ihre Artikeln ohne Voranzeige vorzunehmen.

FABAR S.r.l. se réserve le droit d'apporter à ses articles les modifications qu'elle jugera utiles sans préavis.